

Manual SG553 M-LOK Handguard



Description:

This SG553 M-LOK handguard is developed to mount attachments on the M-LOK-interface to the rifle (check matching models). It is possible to mount attachments directly to the M-LOK interface or with M-LOK rails (separately sold) which provide a picatinny 1913 or STANAG 4694 interface.

Technical Data:

STANAG 4694 rail:

M-LOK positions:

Dimensions:

Weight:

Colour:

Matching models:

1 Position (12 o'clock)

5 Positions (2, 3, 6, 9 and 10 o'clock)

177 x 75 x 48mm

239g

black, (different colours can be offered)

SG552 / SG553 / SG553R / SG553BK

All Variants of the upper receiver
(Diopter, rail Gen. 1, rail Gen. 2)

Handguard

Box contents:

Handguard consists:

Handguard upper assembly:

- 1) Handguard upper part
- 2) Stock locking
- 3) Spring block

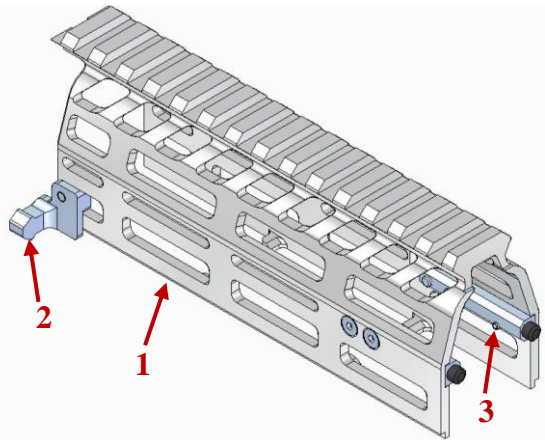

Handguard lower assembly:

- 1) Handguard lower part
- 2) Mounting point
- 3) Slide
- 4) Spring
- 5) Guide rod
- 6) Guide rod holder

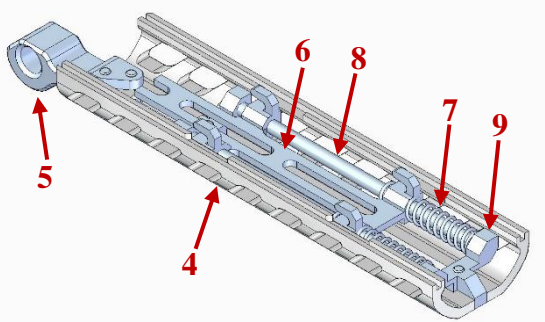

M-LOK Rail (sold separately):

- 7) M-LOK 5 slot rail
- 8) Screw
- 9) M-LOK Nut

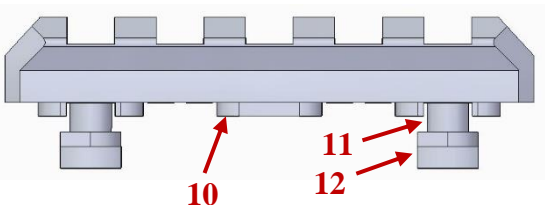

Assembly instructions:

Step 1: Preparation

- 1a. Make sure the gun is unloaded, remove the magazine and check the chamber.
- 1b. Remove mounted Handguard as usually.
- 1c. Remove charging handle.



Step 2: Opening the handguard

- 2a. Unscrew the silver, cross slot screw of the drop safety at the bottom as far as possible.
- 2b. Slide the charging handle through the thin slot on the lower assembly.
- 2c. Push and hold the charging handle to the front.
- 2d. Separate the two handguard

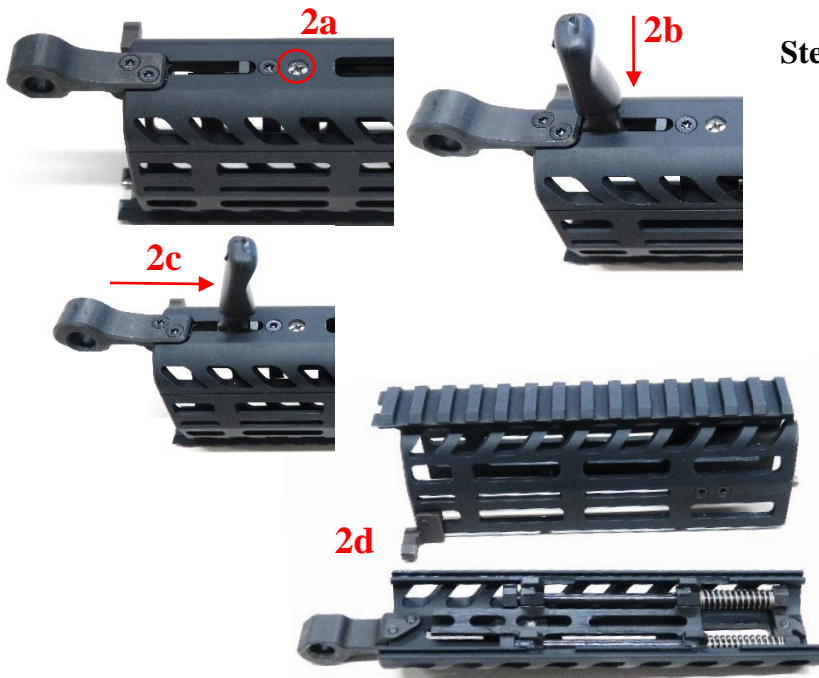

Step 3: Mounting upper handguard assembly

- 3a. Position the upper handguard assembly.
- 3b. Push forward, so that the spring blocks give in, then push down.
- 3c. Mount the upper handguard in the front collar.
- 3d. Position the upper handguard assembly as shown in the picture.
- 3e. If the rifle has a rail on the upper receiver, you need to position as following:
 - Gen. 1: the handguard has to be positioned in front of welded rail.
 - Gen. 2: the handguard has to be positioned in front of welded rail, so the extension from the rail fits in the gap of the handguard.

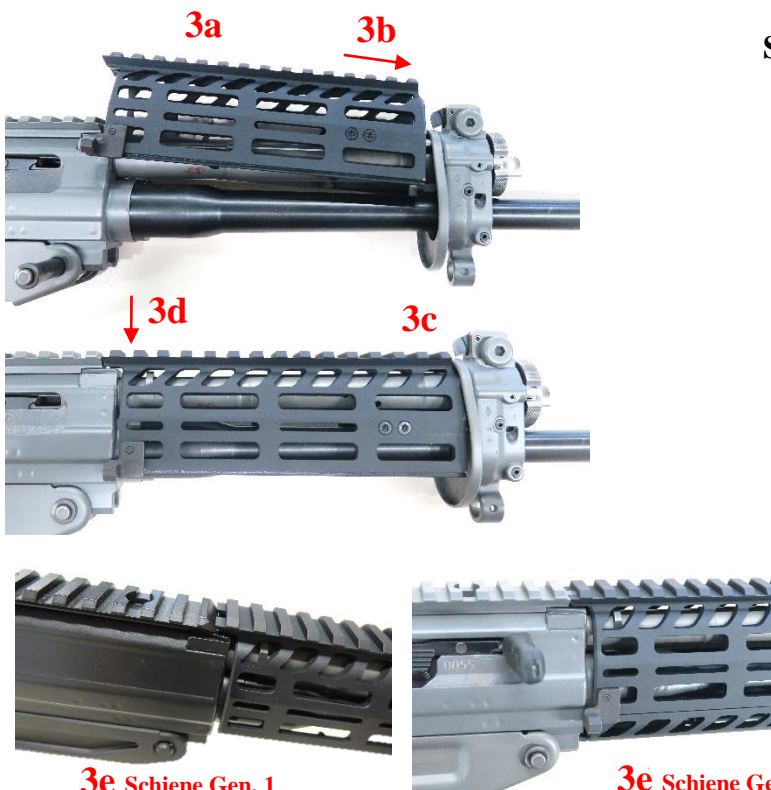

3e Schiene Gen. 1

3e Schiene Gen. 2

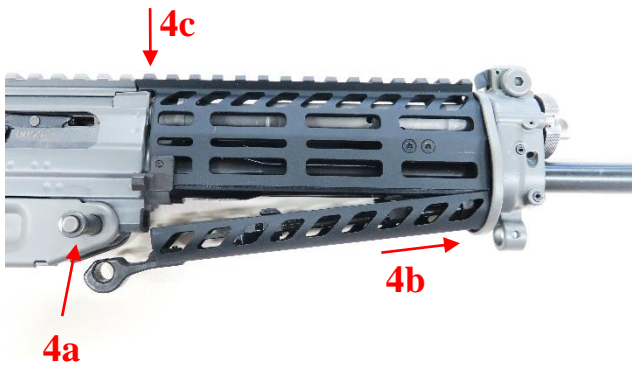

Step 4: Mount lower handguard assembly

- 4a. Mount handguard lower assembly in the front collar.
- 4b. Make sure the pushpin is pulled out.
- 4c. Fix the handguard upper assembly in place.
- 4d. Position the handguard lower assembly as shown in the picture.

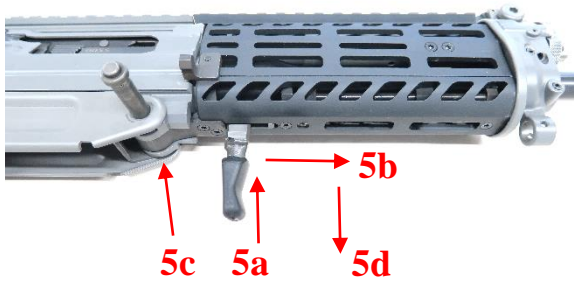

Step 5: Fix lower handguard assembly

- 5a. Slide the charging handle again through the thin slot on the lower assembly.
- 5b. Push and hold the charging handle to the front.
- 5c. Push the lower handguard assembly upwards.
- 5d. Remove the charging handle, so the slide locks in place.

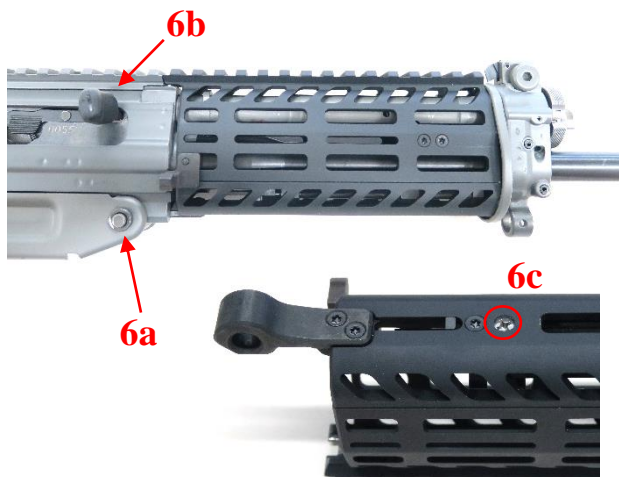

Step 6: Finish

- 6a. Mount pushpin as usually.
- 6b. Mount charging handle as used in the bolt.
- 6c. Screw the silver, cross slot screw of the drop safety at the bottem in as far as possible.

Variants of the upper receiver:

Diopter-Variant:

No stabilisation with the upper receiver.



Rail Gen. 1:

Partially stabilisation with the upper receiver, height difference between the Picatinny / STANAG rails, rail not continuous.



Rail Gen. 2:

Optimal positioning and stabilisation with the upper receiver, continuous STANAG 4694 rail.

